

General Installation Considerations

- 1) Area in which display is to be sited must have a minimum room volume no less than 66 cu m (CTD2HT), 82 cu m (CTD3HT) or 95 cu m (CTD4HT).
- 2) Install over a sealed floor or ventilated floor void.
- 3) Do not site the display within 2m of ceiling mounted air conditioning grilles.
- 4) Do not site the display beneath a high level of direct sunlight.
- 5) Display will operate in a 24 hour environment.
- 6) Access to maintain condensing unit should be made via removable fascia panels or doors to customer and operator side of counter.

A) WORKTOP CUT-OUT

Model Ref.	Worktop Cut Out Size (mm)		Model Weight (in Kg)
	Length	Width	
CTD2HT + AF1	795	650	111
CTD3HT + AF1	1145	650	133
CTD4HT + AF1	1495	650	161

FIX LIFTING BRACKETS TO FRAME END FLANGES USING SCREWS ALREADY IN FLANGES, THEN LOCATE LIFTING BARS INTO SQUARE HOLES.

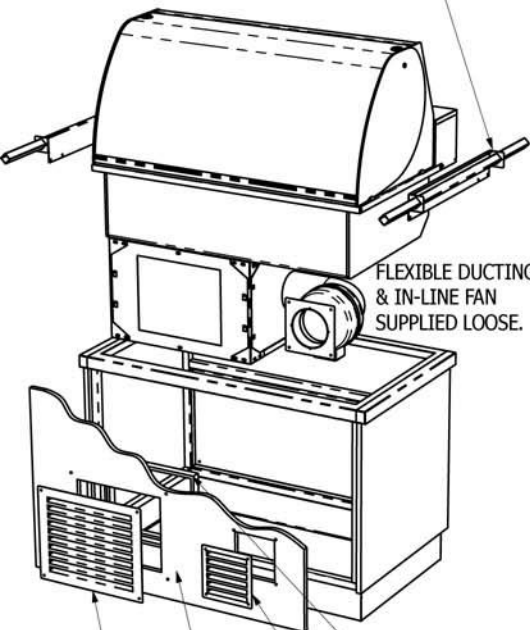

FLEXIBLE DUCTING & IN-LINE FAN SUPPLIED LOOSE.

- REMOVABLE FASCIA PANEL (BY OTHERS)
- STANDARD STAINLESS STEEL AIR GRILLE (SUPPLIED BY CED)
- PLENUM OR 4 SIDED TUNNEL (BY OTHERS)
- STAINLESS STEEL AIR FLOW KIT GRILLE (SUPPLIED BY CED)

FRONT ISOMETRIC (CUSTOMER SIDE)

B) AIR INTAKE & OUTLET CUT-OUTS (CUSTOMER SIDE FASCIA PANEL)

(FOR CTD2HT - CTD4HT)

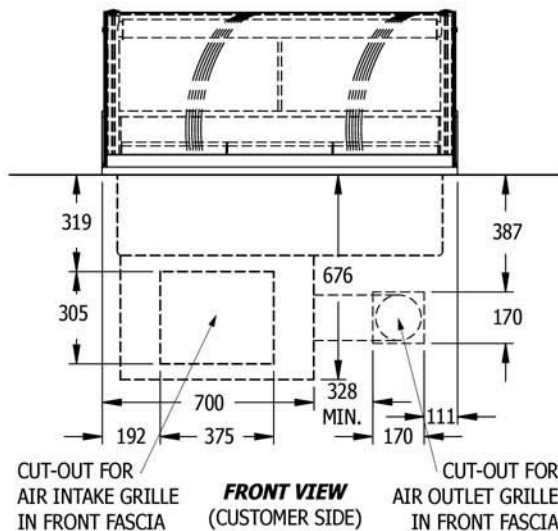

CUT-OUT FOR AIR INTAKE GRILLE IN FRONT FASCIA

FRONT VIEW (CUSTOMER SIDE)

CUT-OUT FOR AIR OUTLET GRILLE IN FRONT FASCIA

D) AIR INTAKE TUNNEL / PLENUM FITTING (CUSTOMER SIDE FASCIA PANEL)

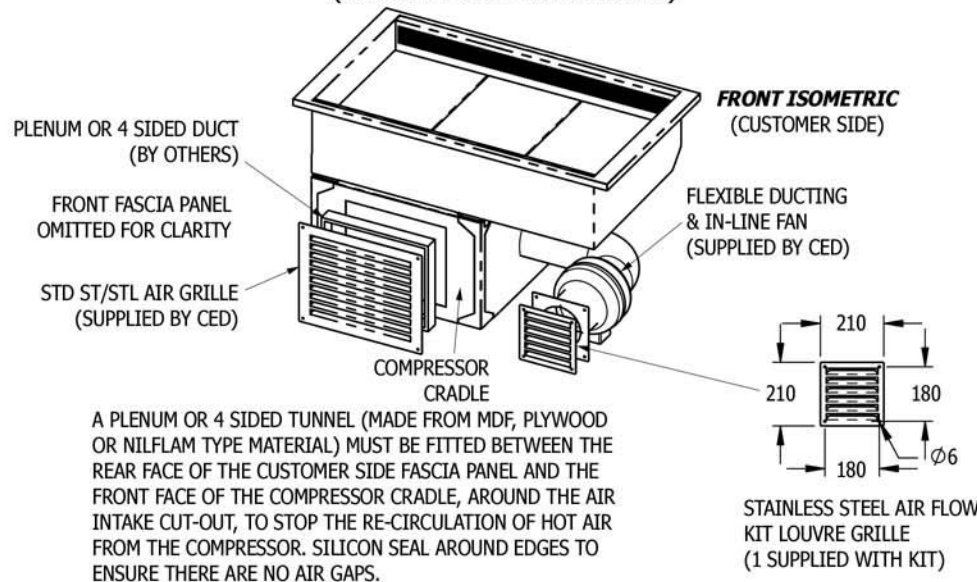

C) FITTING INTO COUNTER WORKTOP

RE-ATTACH FLEXIBLE DUCTING & IN-LINE FAN TO SIDE OF COMPRESSOR CRADLE ONCE UNIT HAS BEEN DROPPED INTO PLACE. ELECTRICALLY CONNECT FAN TO CONTROL BOX WITH "KETTLE PLUG"

REMOVE LIFTING BRACKETS AFTER FITTING AND REPLACE SCREWS INTO FRAME END FLANGES

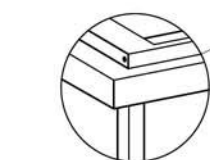

SILICON SEAL AROUND DISPLAY FLANGE TO COUNTER WORKTOP

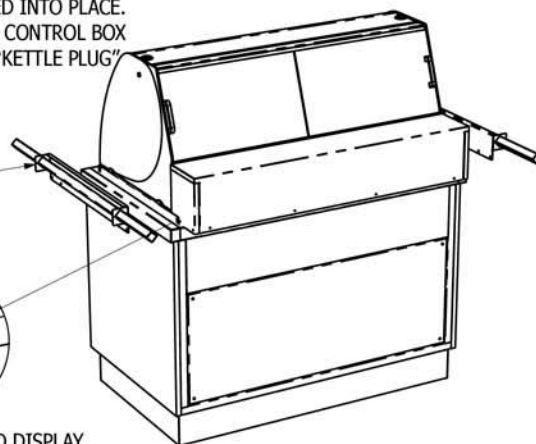

REAR ISOMETRIC (OPERATOR SIDE)

E) FITTING OF LOUVRE GRILLES

