

Table Top Hot Merchandiser (Inclined Shelving)



ABOUT

The energy efficient, hot merchandiser is factory pre-set at 75°C and offers customers two tiers of independently controlled grab n' go hot food holding, within a minimal 763mm (w) x 715mm (d) x 771mm (h) footprint.

This 13A heated self help s/steel display is finished in a signature food safe black coating & is ideal for the display of pre-heated cooked food, packaged, cartoned or unwrapped heated product. The table top heated merchandiser features digitally controlled static shelf heating to maintain food core, whilst variable, jacketed infrared top heat surrounds the food surface. Removable s/ steel wire grid shelf covers allow heat circulation around packaged food types. Removable steel bar dividers, also included allow food to be stored in rows.

Panoramic product display is provided through glazed side panels which also offer environmental side draught protection. The temperature of each heated zone can be independently set using its' own digital display & infrared top heat regulator, each mounted in the operator side base. Product temperature is maintained at 70 - 75°C in +18°C ambient.

In quieter serving periods, upper or lower zones can be independently switched off to conserve energy use. A branded header panel with vinyl transfer can be provided.

This open faced, rear loading merchandiser operates with a max. 2.85 kW power supply when both zones are operating. It is ergonomically designed with 'touch safe' extruded aluminum shelf and canopy edges to allow serve through or grab n' go use at counter top height.

The merchandiser can be used either front of house as a short term food set down point, or a hot holding area for wrapped/ unwrapped pre-heated goods. The unit is stabilised with rubber feet and features a 2m lead and UK 13A plug top (230v 50 Hz). A 40mm (H) ticket strip mount is provided to each shelf front.

FEATURES

Model Size.

The DTTHM2 heated merchandiser is an open fronted hot display, available in 763mm (L).

2 Zone Storage Capacity: 2 Tier Hot Shelving With Overhead Heating.

The display features 2 no. angled heated shelves, each with overhead jacketed infrared top heat lamps. Both upper & lower zones are independently controlled, have removable wire steel shelf grid covers for use with packaged & cartoned heated produce. The display area is finished in food safe polyester coated steel. Removable steel bars allow food to be stored in rows. A 40mm (H) ticket strip mount is provided to each shelf front.

Energy Saving Facility.

For certain less busy serving periods, upper or lower zones can be independently switched off to conserve energy use.

Model Type: Self Help Hot Merchandiser (Open Rear).

Open fronted display for either short term food set down or grab n' go. Re-stocking access is by open rear. The temperature of each heated zone can be independently set using its' own digital display & infrared top heat regulator, mounted in the operator side base

Panoramic Glass Sides.

Side glass panels provide panoramic product display, offer environmental side draught protection & add natural lighting.

Model Dimensions.

763mm (L) x 715mm (D) x 771mm (H).

Recessed Shelf Dimensions.

637mm (L) x 558mm (D) x 230mm (H). A 40mm (H) ticket strip mount is fitted to each shelf.

System Design.

Static heating maintains food core, whilst variable jacketed, overhead infrared top heat lamps surround the food surface. Stainless steel wire grid covers allow heat circulation around packaged food types. Removable steel bar dividers allow food to be stored in rows.

Temperature Performance.

Factory set for 70 - 75°C (+18°C ambient), each display zone temperature is adjustable.

Temperature Controls.

Each heated zone can be independently set using its' own digital display & infrared top heat regulator, mounted in the operator side base.

Mains power to each zone is controlled by separate neon on/off switch.

Finishes.

430gd food safe polyester coated s/steel in black (Ral 9005). Toughened glass side screen panels. 2x removable stainless steel wire shelf grid covers per zone (each 553 x 299mm).

Power Supply.

Supplied with 2m lead & 13 amp UK plug (13A 230V 50Hz) 2.85 kW.

Low Maintenance.

Easy, cleanable surfaces and a durable design ensure low maintenance for users.

Equipment Conformity.

CE & UKCA Certified equipment.

FOOD TYPES

Food (Shelving Area):

Packaged or unwrapped fries, pies, pastries, sausage rolls, hot dogs, stews, curry, chilli dishes, grilled sandwiches, hot baguettes, hot ciabatta, pasta in sauce, ribs with sauce, chicken portions, pizza slices.

40mm (H) ticket strip mount

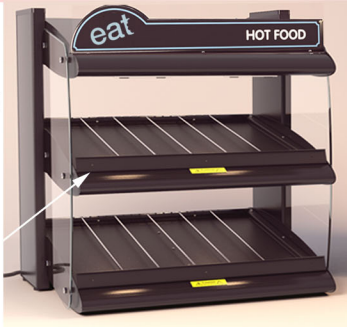

SPECIFICATION

Code	Description	Dimensions (L x D x H mm)	Weight (kg)	Power Rating (kW)
DTTHM2	Table Top Hot Merchandiser	763 x 715 x 771	31	2.85

Model Description.

Heated table top merchandiser, self help, (2) heated shelving, (1) canopy head, open fronted, open rear, 763mm W x 715mm D x 771mm H, variable static base heat & overhead jacketed infrared variable heat, (2) independently operated heat zones, digital control panels/ dimmer switches each zone, controls to operator side, (2) polyester coated fixed angle shelves, (4) removable wire steel shelf covers, (10) removable s/steel rod shelf dividers, s/ steel construction finished in food safe polyester coated black (Ral 9005), 40mm (H) ticket strip mount to each shelf front, toughened side glass, mounted on rubber feet, CE/UKCA, 2m lead/UK Plug (13A 230V 50 Hz 2.85kW).

DIMENSIONS

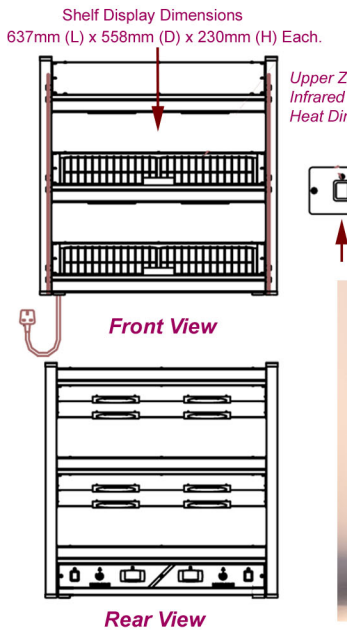
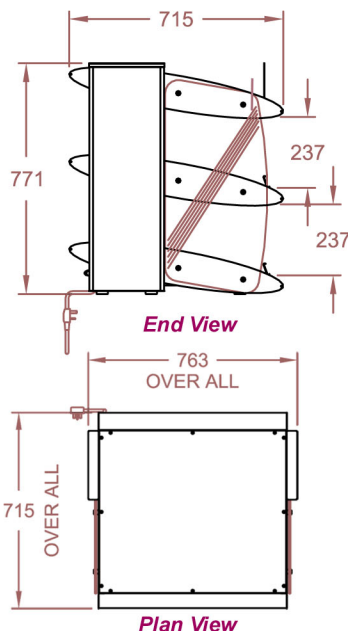

CONTROL PANEL DETAILS

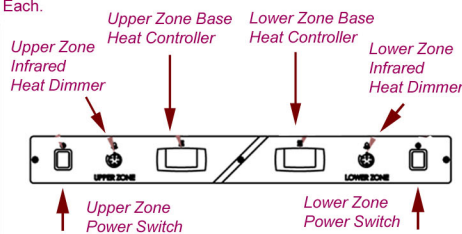

OPTIONS

(Option DBH2) Graphics Header Panel
Brand header graphics mounting panel, 680mm (w) x 122/85mm (h) – powder coated black

(Option DVG2) Vinyl Graphic Label
Vinyl graphic label, 680mm (w) x 122/85mm (h), supplied to artwork provided. Applied to brand header graphics mounting panel. MOQ 10 units

(Option DCOL2) Alternative Colour
Alternative ral colour to black (Ral 9005)

(Option DGDR2) Rear Lift-Up Glass Doors
Rear hinged glass (6mm) lift up doors (set of 2) 4 no.