

ORIGINE
FRANCE®
GARANTIE



TOURNUS EQUIPEMENT - PRICE LIST 2025

HOT HOLDING CABINETS · RACKING · GN TROLLEYS · PLUS MANY MORE

CED & Tournus together better

Our recent merger with French catering equipment manufacturer Tournus, now enable CED to extensively increase our product range like never before, introducing many innovative quality products – all with short lead times and delivered direct to site, with other equipment currently supplied by CED.

The new partnership brings with it, more than 100 years' experience in commercial catering equipment design & manufacturing, supplied worldwide from our state of the art production facility in the Burgundy region of France.

CED & Tournus will continue to invent, invest and give our customers competitive quality catering solutions, for many years to come.

Howard Rishton
Managing Director



CONTENTS

Roll'Service

- Hot holding banquet trolley with humidification control.....10
- Hot holding banquet trolley without humidification control.....11

Trolleys

- Serving trolleys..... 14-15
- Plate lowerators.....16
- Glasses or tray dispenser trolleys.....17
- Self-service trolleys.....18-19
- Rack and tray dolleys.....20
- GN Container storage trolleys 21-22

Shelving

- Racking with removables shelves..... 28-32

Hygiene

- TS 2000N hand wash basins 36-37
- G.A. wash hand bowls.....38
- G.C. wash hand basins.....38
- Mobile wash hand basins.....39
- Janitor sink stations.....39
- Sterilizing cabinets.....41
- Waste bag holders & bins.....42-43

Others products

- Bread making units.....44-46
- Wall shelves.....47
- Catering high cupboard48
- Ergonomix 50-51



Proof of commitment

French Origin Guarantee

The Guaranteed French Origin label promoted by the Pro France association is based on a stringent standard drawn up in 2011. Guaranteed French Origin ensures the consumers that the product bearing this logo has been manufactured in France. This guarantee, validated by a certifying body is based on a specification made up of 2 cumulative criteria:

- for industrial products, manufacturing should effectively take place in France: the product takes on its essential characteristics and distinctive form in France.
- 50% to 100 % of the unit cost price of these products are achieved in France The cost price includes the production cost and the costs related to research and development

Applicants therefore undertake to adhere to the social, environmental and health standards in force. The list of products currently recognised as OFG is available from www.nosachatsfrançais.com



NF Food Hygiene

The NF Food Hygiene certification stems from a voluntary initiative from manufacturers. This standard applies to equipment intended for mass catering and bakery-confectionery refrigerated equipment. This is an acknowledgement of the quality of the products, certified by AFNOR, a specialised body. The NF - Food Hygiene Certification:

- Guarantees the quality of materials intended for food contact.
- Certifies products can be easily cleaned. Backed by guidelines relating to each type of equipment, it guarantees that the equipment is quick and easy to clean in order to prevent dirt traps for bacteria to grow.
- Guarantees thermal, refrigeration and isothermal performance of appliances to ensure that the temperature rising and lowering times are adhered to as well as the storage temperatures.
- Guarantees the sealing of the refrigeration circuit of products in compliance with the European regulations relating to refrigerants.
- It therefore contributes to the prevention of foodborne diseases and facilitates the setting up of an HACCP system with the emphasis on end user food safety.



ISO 9001 certification

The ISO 9001 certification, delivered by an accredited body, certifies the company's quality management system and ensures international acknowledgement.

Guarantee of professionalism: the ISO 9001 procedure is aimed at implementing a customer-centric quality policy, laying down relevant targets and rounding up the human resources to achieve these efficiency targets. The standard promotes an organisation involving all the players across the company.

On-going improvement: ISO 9001 defines the requirements aimed at zero defect by reducing failures, errors, non-compliances and complaints.

Demanding procedure: companies undertake to comply with the deontological, ethical, regulatory and legal requirements in force.



ISO 50001 certification

ISO 50001 certification is a management tool that enables evaluation of a company's energy expenditures, implementation of an energy consumption metering plan, improvement of energy performances, and innovation in investment choices. This certification entails the involvement of our entire factory and therefore concerns all our products manufactured in Tournus. We have been working on enhancement of our manufacturing processes and the optimisation of efficiency of the energy consumption of our machines. The Building Management System has been modernised, with more efficient management of lighting and heating.

Implementation of this ambitious plan aims to achieve a **20% energy saving by 2020**. The more rationalised use of energy will contribute to the development of a sustainable and efficient operation, preserving the environment and natural resources, while at the same time contributing to the company's competitiveness



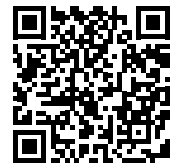

Flash on our certifications

LONGTIME® Certification

LONGTIME® endorses our ability to develop products « designed to last over time ». This implies that they are robustly designed, easily repairable, and that sensitive parts (fans, boards, electronics, etc.) are easily accessible and replaceable. The availability of after-sales service parts, even more than 10 years after the sale of the product, the quality and accuracy of documents, manuals and spare parts catalogues are decisive criteria for obtaining this label. **This labelling is exclusive to our Rolls' Service, Roll'Fresh, Temp'Up and oreo self-service lines.**



CE Marking

The CE marking materialises **the compliance of products** with the requirements laid down to manufacturers by the European Union. It entitles products to free movement throughout the European Union and the right to be used therein. **The European Directive** relating to the CE marking relates in our profession to low voltage electrical appliances, appliances emitting electromagnetic waves, machines and gas appliances. The CE mark is compulsory for these products.



NSF Certification

NSF International is an independent certification body committed to public health safety and environmental protection. The NSF mark certifies that this product has been recognised as complying with the international food industry standards. Manufacturers undergo strict assessment, products are tested and factories spot-checked. **The NSF standard is based on products that can be easily cleaned. It vouches for the company's commitment to quality, product compliance and consumer safety.** Only for TS15 tables and shelving.



Member of the Synetham

Synerg and Unitam merged to become SYNETAM. The objective is to unite in order to bring together, defend and promote, under the same banner, catering and culinary arts equipment suppliers: kitchen, cutlery, tableware, laundry and smoke ducts. This union aims to develop the entire manufacturing profession, through the promotion of trades and businesses, in France and internationally. Synetam now represents 87 manufacturers with a turnover of □1.5 billion. As a signatory of the Synetham quality charter, Tournus Equipement undertakes in particular to respect the application of the following points:



- Marketing of equipment strictly complying.
- Equipment manufactured adhering to environmental protection and ethical requirements (no exploitation of children, freedom of trade union, no discrimination, workplace health)
- Personalised assistance in the choice of equipment adapted to user requirements.
- Specialist advice for the layout and optimum operation of appliances.
- 10-year guarantee of availability of OEM parts or parts certified as in compliance.
- Coverage of public liability insurance.
- The supply of instructions for installation, start-up, use and maintenance supplied with the equipment.

Resto France Expert

Resto France Experts (RFE) is the new catering engineering association that brings together design firms, but also other players contributing to the success of hotel and catering projects (from equipment to hygiene advice, nutrition, ergonomics, logistics, training, legal, digital, communication, etc.). The aim is to pool skills and promote know-how in France and abroad. Today, Resto France has about 60 member companies with multiple skills. Tournus Equipement is one of the 9 founding members of RFE, of which we are also a director.



Member of th Cetim

Furniture commission (centre Technique des Industries mécaniques). **Taking part in joint work:** stainless



Sustainable initiative

For Professionals

The “carbon” footprint

The carbon footprint demonstrates a reliable and measurable industrial undertaking: a quality-related assessment criterion in terms of calls for tender. Improvement measures: implementation of eco-design projects, use of AISI 441 stainless steel, raising good practices awareness in the use of our energy units. **Tournus Equipement is the only factory in the food service industry to have performed a « carbon footprint ».**

AISI 441 stainless steel

Tournus has incorporated AISI 441 stainless steel into its production. With a quality identical to AISI 304, it emits less Greenhouse Gases during production: -14 %. A set of equipment made of AISI 441 can be recovered in a sustainable development oriented project without losing in performance or creating additional costs.

Energy performance

The design of the Oreo2 self-service solution enables power consumption savings of approximately 40% compared to the old range, with identical performance and comfort of use. **This avoids approximately 1200 tonnes of CO² emissions per year.**

Assistance to professionals

Tournus Equipement makes product sheets available to its customers to help decision-makers in their HQE projects. They specify the materials used and the respective weight, the water consumption, energy consumption, worksite waste and the parts that can be recycled in each product.

The « Environment » sheets can be integrated into the as-built file. They are used to define a minimum recycling rate of the equipment implemented.

LONGTIME® Certification

LONGTIME® is the first European label that identifies and promotes products that are designed to last, thanks to a method of evaluating the durability of products based on the EN 45552 and EN 45554 standards. The LONGTIME® label fights against premature obsolescence and supports the expansion of the circular economy. **LONGTIME® endorses our ability to develop products « designed to last over time ». This implies that they are robustly designed, easily repairable, and that sensitive parts (fans, boards, electronics, etc.) are easily accessible and replaceable. The availability of after-sales service parts, even more than 10 years after the sale of the product, the quality and accuracy of documents, manuals and spare parts catalogues are decisive criteria for obtaining this label.**

CO² saving

For every big job or simple request, Tournus Equipement forwards customers a statement of the savings of CO² emissions with the estimate.

This particularly enables clients to reply to calls for tenders integrating environmental requirements.

The use of refrigerant fluid R455A

Refrigerant fluid R455A is Tournus Equipement's standard fluid..This is because, with a GWP of 3900, R404A is too polluting, has become too rare and too expensive and will soon be banned by the regulation. **With a GWP <150 compliant with the F-Gas Regulation. Thermal performance identical to R404A. 10% decrease in electricity consumption.**



ROLL'SERVICE

HEATED TEMPERATURE HOLDING BANQUET TROLLEY



Easy loading:

270° door opening.

Door stay system:

easier loading

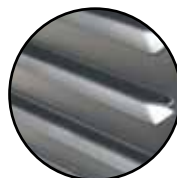

Hygienic:

curved surfaces and press-drawn sliders. Space between sliders: 71 mm.



Optimum temperature distribution:

centrifugal fan.



Easy operation:

removable, 2 litre condensate tank, front access. 24-hour operation.



Easy access to functions and settings:

temperature control (range from 60°C to 85°C), humidity control (35 % to 50 %), **IP 25**.



2 Side handles and one bar at rear for easy handling.



Ergonomic:

exclusive modern, oversized handle.



Maintenance:

easy access to technical parts.



Easy handling:

4 swivel wheels, 2 with brake.

Non-marking shockproof surround:

protection of the cabinet and its surroundings.

Compact: small footprint

- 1/1 GN: 528 x 821 mm
- 2/1 GN: 733 x 941 mm



Scan here for documentation

* Condensate drip system not available for 5 level model







ROLL'SERVICE

HEATED TEMPERATURE HOLDING BANQUET TROLLEY

Heated temperature holding banquet trolley. Made of food quality stainless steel with rock wool insulated walls and door. Electronic control thermostat with digital display. Inside entirely radiused, with press-draw sliders and base. Space between sliders: 71 mm. Stainless steel or glazed door, with removable seal (opens 270°). Carrying handles on sides and rear guide bar.

Non-marking, shock-proof surround (5-level model fitted with corner bumpers). 4 braked wheels, 2 braked, Ø 160 mm stainless steel cover on 20 level 2/1 GN models, Ø 125 mm polyamide cover on 10 and 15 level 2/1 GN models, 10,15 and 20 level 1/1GN models, and Ø 80 mm wheels with stainless steel cover on 5 level models. Index of protection IP25, for low pressure cleaning. NF-Hygiene Certified.

Electric heating system: heating provided by a centrifugal fan to the rear, with external motor which circulates air through sealed stainless steel heating elements. Stainless steel internal air deflection system. Regulated temperature at 85°C. The electronic regulation thermostat with digital display allows a regulation from 60 to 85°C. Features a fast rise in temperature feature, from 20 to 85°C in 25 minutes. Supplied with spiral cable and moulded plug for electrical connection, Voltage 230V, rate 50/60 Hz.

- **Condensate drip system** (except for the 5 level Roll'Service).
- **Door stay system:** easier loading thanks to the new door stay system in open position.

ROLL'SERVICE - WITH HUMIDIFICATION CONTROL

The electronic control allows selection of 5 rates of hygrometry. Removable rotomoulded tank accessible from the front, with 2 litre capacity, allowing 24 hour operation.



507 356

507 357

Roll'Service 1/1 GN

ROLL'Service	Electrical consumption (kwh) (1)	Input power (kW) (2)	Capacity (litres)	Overall dim. l x W x h (mm)	Reference	Price
10 levels with s/steel door	0,29	0,825	146	528 x 821 x 1134	507336AS	£7,134
15 levels with s/steel door	0,30	1,215	215	528 x 821 x 1489	507356AS	£7,720
15 levels with glass door	0,30	1,215	215	528 x 821 x 1489	507357AS	£8,441
20 levels with s/steel door	0,575	1,215	284	528 x 821 x 1844	507386AS	£8,322
20 levels with glass door	0,575	1,215	284	528 x 821 x 1844	507387AS	£8,847



507 457

507 486

Roll'Service 2/1 GN

ROLL'Service	Electrical consumption (kwh) (1)	Input power (kW) (2)	Capacity (litres)	Overall dim. l x W x h (mm)	Reference	Price
10 levels with s/steel door	0,410	1,215	285	733 x 941 x 1134	507436AS	£8,152
15 levels with s/steel door	0,405	1,215	420	733 x 941 x 1489	507456AS	£8,855
15 levels with glass door	0,405	1,215	420	733 x 940 x 1489	507457AS	£9,590
20 levels with s/steel door	0,785	2,015	555	733 x 941 x 1880	507486AS	£9,874
20 levels with glass door	0,785	2,015	555	733 x 941 x 1880	507487AS	£10,320

(1) average electrical power consumption per service (as per NF 040 016 for a 3h30 cycle)

(2) maximum start up power required.



ROLL'SERVICE - WITHOUT HUMIDIFICATION

Condensate drip system
* not available for 5 level model

Roll'Service 1/1 GN

ROLL'Service	Electrical consumption (kwh) (1)	Input power (kW) (2)	Capacity (litres)	Overall dim. l x W x h (mm)	Reference	Price
5 levels with s/steel door	0,22	0,825	77	524 x 817 x 708	507301AS	£5,663
10 levels with s/steel door	0,29	0,825	146	528 x 821 x 1134	507331AS	£6,528
15 levels with s/steel door	0,30	1,215	215	528 x 821 x 1489	507351AS	£7,104
15 levels with glass door	0,30	1,215	215	528 x 821 x 1489	507352AS	£7,896
20 levels with s/steel door	0,575	1,215	284	528 x 821 x 1844	507381AS	£7,745
20 levels with glass door	0,575	1,215	284	528 x 821 x 1844	507382AS	£8,264



Embossed chute

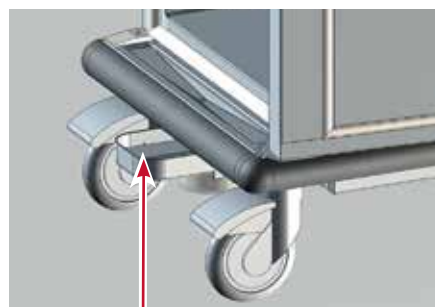

Removable and retractable condensate drip system



805 081

Roll'Service 2/1 GN

ROLL'Service	Electrical consumption (kwh) (1)	Input power (kW) (2)	Capacity (litres)	Overall dim. l x W x h (mm)	Reference	Price
10 levels with s/steel door	0,410	1,215	285	733 x 941 x 1134	507431AS	£7,539
15 levels with s/steel door	0,405	1,215	420	733 x 941 x 1489	507451AS	£8,264
15 levels with glass door	0,405	1,215	420	733 x 941 x 1489	507452AS	£8,971
20 levels with s/steel door	0,785	2,015	555	733 x 941 x 1880	507481AS	£9,202
20 levels with glass door	0,785	2,015	555	733 x 941 x 1880	507482AS	£9,743

(1) average electrical power consumption per service (as per NF 040 016 for a 3h30 cycle)

(2) maximum start up power required.

Options

Description	Reference	Price
Extra-cost for lock and key	701 961	£138
Extra-cost for reverse opening door*	701 963	£387
Extra-cost for 4 swivel stainless steel wheels Ø 125 mm including 2 brakes to replace wheels with polyamid cover	702 190	£217
Tournus Grid, 1/1 GN, stainless steel	805 081	£22

* special manufacture, not from stock, no longer allows the key lock.



507 481



507 452



507 431



507 301



Option:
Lock and key.

TROLLEYS



Serving trolleys

- **Safe transport:**
press-drawn trays 10 mm deep for optimum holding of containers.
- **Comfort:**
sound-proofed trays.
- **Sturdiness:** welded assembly over the whole tray height with flattened edges in lower part.

Plate trolley

Raised platform

- **Sturdiness:**
Bent square (25 x 25) tube and bent sheet metal with flattened edges. Stainless steel structure.
- **Ergonomical:**
platform height: 460 mm (200 plates) and 485 mm (400 plates).



Quick heating time and evenly distributed temperature.

Heated trolleys

- **Easy use:**
no tools required to adjust plate diameter (up to 320 mm).
- **Quality of steering**
silent, easy sliding, reliability
- **Easy cleaning:**
removable heated sections for deep cleaning.

GN racking trolleys

- **Strength:**
load 250 kg per trolley
- **Sturdiness:**
continuous welded sliders over the whole height.
- **Optimum accessibility**
longitudinal reinforcement bar not necessary at the front.
- Swivel wheels
Ø 125 mm with non-marking tyre, soundless.

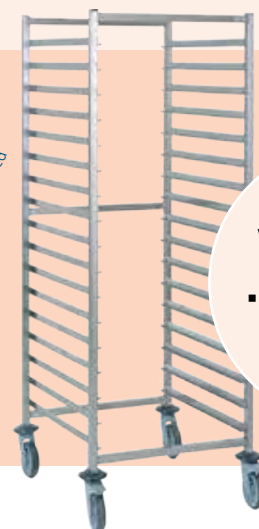

Wheels with polyamide Ø 125 mm:

- Noiseless wheels
- Less inertia on starting



Scan here for documentation



TOURNUS
EQUIPEMENT





SERVING TROLLEYS



Stainless steel welded construction. Stainless steel trays with rounded edges, sound-proofed trays. Arched handles: tube Ø 25 mm. 4 swivel wheels Ø 125 mm with polyamide cover including 2 brakes, with annular bumpers. Non-marking rubber tyres. Max load: 50 kg by level. Hygiene certified.



801 542

Serving trolleys with 2 arched handles

Serving trolleys with 2 arched handles	Overall Dim. l x W x h (mm)	Space between trays	Ref.	Price
2 trays 800 x 530 mm	895 x 625 x 960	560	<u>801 542</u>	£427
3 trays 800 x 530 mm	895 x 625 x 960	260	<u>801 543</u>	£524
4 trays 800 x 530 mm	895 x 625 x 1260	260	801 544	£741
2 trays 1000 x 600 mm	1095 x 695 x 960	560	<u>801 552</u>	£511
3 trays 1000 x 600 mm	1095 x 695 x 960	260	<u>801 553</u>	£657
4 trays 1000 x 600 mm	1095 x 695 x 1260	260	801 554	£909



- Press-drawn trays with peripheral surround of 10 mm.
- Tray width of 530 mm for efficient holding of a GN container and optimum safety of use.

Serving trolleys with 1 arched handle

Serving trolleys with 1 arched handles:	Overall Dim. l x W x h (mm)	Space between trays	Ref.	Price
2 trays 800 x 530 mm	895 x 625 x 960	560	801 602	£452
3 trays 800 x 530 mm	895 x 625 x 960	260	801 603	£548
2 trays 1000 x 600 mm	1095 x 695 x 960	560	801 612	£540
3 trays 1000 x 600 mm	1095 x 695 x 960	260	801 613	£678



801 543



801 603





Serving trolleys with 2 arched handles and gallery rails

Gallery rails height 50 mm in stainless steel wire Ø 8 mm, around all 4 sides for each level.



801 547

Serving trolleys with 2 arched handles	Overall Dim. l x W x h (mm)	Space between trays	Ref.	Price
2 trays 800 x 530 mm with gallery rails	895 x 625 x 960	560	801 546	£637
3 trays 800 x 530 mm with gallery rails	895 x 625 x 960	260	801 547	£800
2 trays 1000 x 600 mm with gallery rails	1095 x 695 x 960	560	801 556	£752
3 trays 1000 x 600 mm with gallery rails	1095 x 695 x 960	260	801 557	£958

Accessories



801 395



801 538



801 537

Description	Overall dim. l x W x h (mm)	Reference	Price
Hook-on cutlery pan 1/3 GN	325 x 176 x 200	801 395	£108
Hook-on waste pan	420 x 200 x 250	801 537	£186
Hook-on dustbin bag support 70 litres	360 x 355 x 810	801 538	£206
Trolley covers 895 x 625 mm		229 603	£257
Trolley covers 1095 x 695 mm		229 604	£244



229 603

Options

Description	Reference	Price
Extra cost for serving trolleys with stainless steel wheels	702 180	£251





PLATE LOWERATORS



Stainless steel construction. Rounded inside angles for easy cleaning. Stainless steel steering handle, stainless steel tube Ø 25 mm. 4 moulded polyethylene protective bumpers. 4 swivel wheels Ø 125 mm with polyamide cover including 2 brakes. Removable constant level dispensers, stack height 580 mm, approximately 60 plates Ø 180 to 290 mm.

**Light
Easy to move**



808 171

808 172

Mobile heated plate lowerators

Powered by on/off switch with lamp. Static heating controlled by mechanical thermostat adjustable from 0°C to 90°C. Heated by 2 stainless steel shielded elements located on the sides. Rock wool insulation. Power rating 800 W (1 stack) and 1500 W (2 stacks), voltage 230 V. Trolleys delivered with transparent polycarbonate lids.

Heated plate trolleys	Overall Dim. l x w x h (mm)	Reference	Price
Heated single plate stack type with lids (for plate diam. 180-290 mm).	530 x 485 x 900	808171UK	£1,792
Heated twin plate stack type with lids (for plate diam. 180-290 mm).	960 x 485 x 900	808172UK	£2,549
Heated twin plate stack type with lids (for plate diam. 215-320 mm).	990 x 520 x 900	808177UK	£3,794



808182

Mobile ambient plate lowerators

Option: lids.

Description	Overall Dim. l x w x h (mm)	Reference	Price
Ambient single plate stack type without lid (for plate diam. 180-290 mm).	530 x 485 x 900	808 181	£1,614
Ambient twin plate stack type without lids (for plate diam. 180-290 mm).	960 x 485 x 900	808 182	£2,142



- **Plate holding trays guided** by easy, noiseless rollers.
- **Handling level easily adjusted** by adding or removing springs without using tools.
- **Protection:** bumpers made of non-marking composite material in the 4 corners.

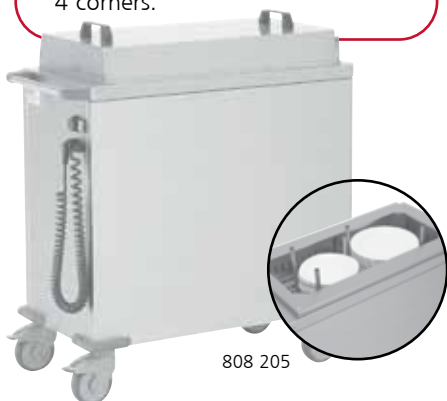

808 205

Mobile universal plate lowerators

Trolleys with rectangular platform for all types of dishes (bowls, saucers, oval or rectangular plates). Heated unit c/w stainless steel lid. Ambient unit is not supplied with lid but is optional.

Description	Overall Dim. l x w x h (mm)	Reference	Price
Ambient universal trolley (open top)	960 x 485 x 900	808 201	£3,232
Heated universal trolley (with lid)	960 x 485 x 900	808205UK	£3,481

Accessories

Description	Overall dim. l x w (mm)	Reference	Price
Transparent polycarbonate lid for ambient single stack lowerator	Ø 375	230 079	£104
Stainless steel lid for ambient universal trolley	750 x 415	119 268	£266



230 079



119 268



GLASSES OR TRAY DISPENSER TROLLEYS

Stainless steel construction. Platform thickness 1,2 mm. Mobile platform guided by 4 guide rolls. 4 swivel wheels Ø 125 mm with polyamide cover including 2 brakes. Moulded polyethylene protective buffers.



Description	Overall Dim. l x W x h (mm)	Reference	Price
Self-levelling glass dispenser trolley with draining pan (GN1/2 polyethylene, depth. 100 mm) under platform 510 x 510 mm with diamond point base, capacity : 6 baskets, height 115 mm or 10 baskets, height 75 mm.	817 x 545 x 930	808 102	£1,273
Self-levelling glass dispenser trolley with draining pan (GN1/2 polyethylene, depth. 100 mm) under platform 510 x 510 mm with diamond point base , capacity : 6 baskets, height 115 mm or 10 baskets, height 75 mm.	817 x 545 x 930	808 100	£2,109
Self-levelling glass dispenser trolley stainless steel surround cover, capacity : 6 baskets 530 x 530 mm, height 115 mm or 10 baskets,height 75 mm	835 x 645 x 1040	808 103	£2,490
Self-levelling tray dispenser trolley platform 540 x 380 mm, capacity: 140 trays	817 x 545 x 930	808 105	£1,263
Self-levelling tray dispenser trolley stainless steel surround and cover capacity: 140 trays 560 x 400 mm	705 x 675 x 1040	808 108	£2,202
Self-levelling tray dispenser trolley with lateral guide, capacity: 140 trays 540 x 380 mm	817 x 545 x 930	808 106	£1,308
Self-levelling trolley for ABS plastic tray capacity: 140 trays 610 x 410 mm	860 x 545 x 930	808 109	£1,283

Options

Description	Reference	Price
Extra-cost for cutlery dispenser fitted to self-levelling tray dispenser trolley	808 107	£174
Extra-cost for 4 stainless steel wheels in lieu of polyamide type wheel (plates, glasses and trays)	702 190	£217
Polyamide cover 870 x 540 x 800 mm for glasses or tray dispenser trolleys	221 233	£222
Polyamide cover 920 x 570 x 1070 mm for cutlery dispenser trolleys	221 232	£334

Drop in dispensers with removable insert

Drop in dispenser capacities: **ambient or heated plate lowerator:** up to 60 plates, 180-290 mm diameter. **Glasses dispenser,** 6 baskets height 115 mm or 10 baskets height 75 mm. **Tray dispenser:** up to 140 trays. Heated lowerator provided with lid & remote control mounting switch.



Description	Overall Dim. l x W x h (mm)	Reference	Price
Ambient single plate stack drop in lowerator without lid (for plate diam. 180 - 290 mm)	Ø 380 x h. 740	<u>808 231</u>	£461
Heated single plate stack drop in lowerator with lid (for plate diam. 180 -290 mm)	Ø 380 x h. 740	<u>808 235</u>	£1,599
Drop in glasses dispenser	690 x 710 x 715	808 236	£2,448
Drop in tray dispenser (for up to 460 x 360 mm tray)	580 x 660 x 715	808 237	£2,299



SELF-SERVICE TROLLEYS

Stainless steel construction. Frame in 25 x 25 mm stainless steel tube. Longitudinal reinforcing bars in 50 x 25 mm stainless steel tube. Wire type tray runner panels in 4.8mm diameter s/steel, welded to frame. With or without beige laminate side modesty panels thickness 2 mm fixed by clips. 4 swivel wheels Ø 125 mm with polyamide cover including 2 braked. Annular bumpers.



800 072



800 075



**Anti-fall clips
for trays
on each tier**

6 tier (tray entry width ways)

Trolley with entry side by side. Capacity: 12 or 18 trays depending on the models.
Space between tiers: 125 mm.



Description	Overall Dim. l x W x h (mm)	Width of trays (mm)	trolleys without panels		trolleys with panels	
			ref	price	ref	price
Trolley 2 x 6 tiers	930 x 630 x 1030	320 - 370	800 071	£1,014	800 072	£1,193
Trolley 2 x 6 tiers with upper shelf	930 x 630 x 1040	320 - 370	800 073	£1,200	800 074	£1,381
Trolley 3 x 6 tiers with upper shelf	1340 x 630 x 1040	320 - 370	800 075	£1,548	800 076	£1,731

12 tier (tray entry width ways)

Capacity: 12 or 24 trays depending on the models. Entry side by side (trolley 2 x 12 tiers).
Space between tiers: 125 mm



Description	Overall Dim. l x W x h (mm)	Width of trays (mm)	Trolleys without panels		Trolleys with panels	
			ref	price	ref	price
Trolley 1 x 12 tiers	510 x 630 x 1790	320 - 370	<u>800 081</u>	£762	800 082	£997
Trolley 2 x 12 tiers	930 x 630 x 1790	320 - 370	<u>800 091</u>	£1,312	800 092	£1,552

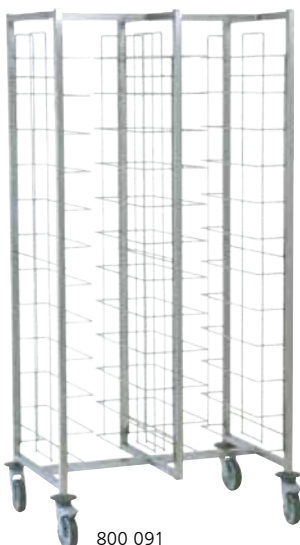

800 091

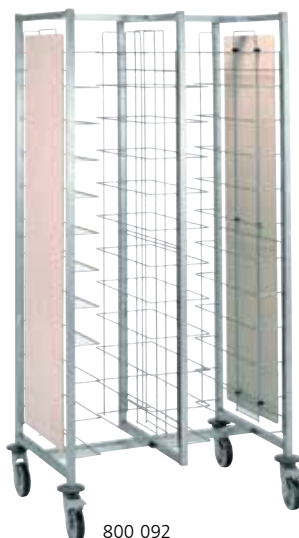

800 092





800 096

12 tier (tray entry length ways)

Capacity: 24 trays, entry back to back.
Space between tiers: 125 mm..



Description	Overall Dim. l x W x h (mm)	Length of trays (mm)	Trolleys without panels		Trolleys with panels	
			Ref	Price	Ref	Price
Trolley 2 x 12 tiers	620 x 790 x 1790	400 - 480	800 093	£887	800 094	£1,251
Trolley 2 x 12 tiers	700 x 790 x 1790	480 - 560	800 095	£893	800 096	£1,256

Extra cost for self-service trolleys with 4 stainless steel wheels - Ref: 702 180 - Price: **£251**

CHOOSE THE MODESTY PANEL COLOUR

The standard side modesty panels of the self-service trolleys are made of 2 mm thick compact beige laminate. You can personalise the cladding of the 2 outsides of your trolleys in one of the colours below (minimum order of 3 trolleys):

- Ref. 702 097, personalised cladding for trolley with 6 tiers, extra charge per trolley: **£280**
- Ref. 702 098, personalised cladding for trolley with 12 tiers with insertion widthways, extra charge per trolley: **£556**
- Ref. 702 099, personalised cladding for trolley with 12 tiers with insertion lengthways, extra charge per trolley: **£840**
- Personalisation is done by bonding a resistive film (cleaning resistant). We offer a choice of 20 colours covering cladding (swatch on request).

Standard colours to match the cladding of dispensing units

Delft blue	Red cherry	Yellow sunflower	Yellow lemon	Green apple	Orange	Fuchsia
Violine	Black	Light concrete grey	Chicago dark concrete grey	Brushed aluminum	Premium white	Alpine white
American maple champagne	Natural bardolino oak	Kendal oak oil	Shorewood	Brown Fleetwood	Walnut of pacific tobacco	

Trolleys can also be personalised with your logo or that of your customers: please make enquiries with us.



RACK AND TRAY DOLLEYS



General purpose basket rack dolley

Stainless steel construction. Base thickness 1,2 mm. Internal base dimensions: 510 x 510 mm. Bolted handle. 4 Ø 100 mm swivel wheels with galvanized steel cover. Max load: 80 kg.

Description	Overall Dim. l x W x h (mm)	Reference	Price
General purpose stainless steel rack dolley	515 x 515 x 165	<u>800 101</u>	£169
General purpose stainless steel rack dolley with handle	600 x 515 x 850	<u>800 102</u>	£239



Heavy duty basket rack dolley (removable ABS base)

Stainless steel construction. Tube 25 x 25 mm. Removable ABS base. Internal base dimensions: 510 x 510 mm. Bolted handle. 4 Ø 125 mm swivel wheels with polyamide cover (includes 2 braked). Annular bumpers. Max load: 150 kg.

Description	Overall Dim. l x W x h (mm)	Reference	Price
Rack dolley with ABS base	570 x 570 x 225	800 111	£266
Rack dolley with ABS base and upstand	630 x 570 x 900	800 112	£331



Heavy duty basket rack dolley (removable steel base)

Stainless steel frame construction 25 x 25 mm. Removable stainless steel base 1,2 mm thick. Internal base dimensions: 510 x 510 mm (rack dolley) and 750 x 510 mm (largest tray dolley). Bolted handle. 4 Ø 125 mm swivel wheels with polyamide cover including 2 brakes. Annular bumpers. Max load: 150 kg.

Description	Overall Dim. l x W x h (mm)	Reference	Price
Rack dolley with heavy duty steel base	570 x 570 x 225	800 125	£283
Rack dolley with heavy duty steel base + bolted handle	630 x 570 x 900	800 126	£349
Rack dolley with heavy duty steel base + bolted handle	870 x 570 x 900	800 130	£405



Options

Description	Reference	Price
Extra-cost for rack and tray dollies with stainless steel wheels (not suitable for general purpose type rack dollies)	702 183	£183
Polyamide cover for rack dollies 530 x 530 x H. 300 mm	230 532	£195
Polyamide cover 750 x 510 x H. 300 mm for trays dollies	221 234	£275



General purpose Euronorm tray dolley (fixed base)

For Euronorm trays or containers 600 x 400 mm. Food quality stainless steel construction. Tray thickness 1.2 mm. Base size 610 x 410 mm. Bolted handle 4 Ø 100 mm swivel wheels with galvanized steel cover. Max load: 80 kg.

Description	Overall Dim. l x W x h (mm)	Reference	Price
Euronorm tray dolley (fixed base)	615 x 415 x 165	800 105	£168
Euronorm tray dolley (fixed base) with handle	700 x 415 x 850	800 106	£263



GN CONTAINER STORAGE TROLLEYS



- **Sturdiness:** max. load 250 kg per trolley and 20 kg per level.
- **Ergonomic:** intermediate brace on trolleys with 10-17-20 levels and GN 2/1 with 15 levels allowing maximum access for front loading.

Stainless steel construction. Square tubes 25 x 25 mm. Welded tray runners with container stop. 4 swivel wheels Ø 125 mm, including 2 brakes, with polyamide cover. Annular bumpers.

Overall dimensions: trolleys 1/1 GN size - 655 x 455 mm, trolleys 2/1 GN - 775 x 660 mm. Trolleys with 6 and 8 tiers include a top shelf. Max load: 20 Kg per tier and 250 Kg per trolley.



GN container storage trolleys

Description	e* (mm)	Height (mm)	Number of tiers	Reference	Price
1/1 GN trolley with top shelf.	81	760	6	<u>804 201</u>	£453
1/1 GN trolley with top shelf.	81	900	8	<u>804 203</u>	£476
1/1 GN trolley	144	1650	10	<u>804 204</u>	£460
1/1 GN trolley	81	1490	15	<u>804 206</u>	£484
1/1 GN trolley	81	1650	17	804 207	£497
1/1 GN trolley	77	1785	20	<u>804 209</u>	£524
2/1 GN trolley with top shelf	81	760	6	804 231	£524
2/1 GN trolley with top shelf	81	900	8	804 233	£534
2/1 GN trolley	144	1650	10	804 234	£494
2/1 GN trolley	81	1490	15	<u>804 236</u>	£550
2/1 GN trolley	81	1650	17	804 237	£565
2/1 GN trolley	77	1785	20	<u>804 239</u>	£574

(*): e: vertical space between tray runners.

Extra-cost for racking trolleys (15,17 or 20 levels) with tie bar - Ref: 702 221 - Price: £241

Extra cost for GN racking with 4 stainless steel wheels (welded, delivered flat packed or stackable) Ref: 702 181 - Price: £251



804 201



804 209



804 237



Transportable GN container trolley

Stainless steel construction. Square tubular uprights 25 x 25 mm. Welded tray runners with container stops at the end. **Full height vertical closing bar for container transport inside a vehicle**, loading, unloading, passing through doors whilst heavily loaded. Ø 125 wheels with non protruding stainless steel cover to take up as little place as possible. Overall dimensions: 583 x 384 mm, height 1485 mm. Space between tray runners 85 mm.

Description	Reference	Price
transport trolley 1/1 GN with 15 tiers	804 212	£1,277



GASTRONORM RACKING TROLLEYS

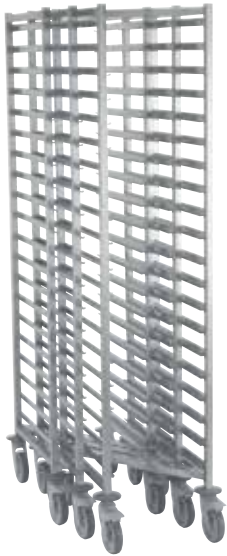

Stackable GN container trolleys

Description	e* (mm)	Overall dim. l x W x h (mm)	Number of levels	Reference	Price
1/1 GN stackable trolley	77	655 x 455 x 1785	20	804 229	£840
2/1 GN stackable trolley	77	775 x 655 x 1785	20	804 259	£884

(*): e: vertical space between tray runners

Washable polyamide covers for GN container trolleys

Covers for 6-8 tier trolleys.
Covers with zip for 10 tier trolleys GN and more

Description	L x W x h (mm)	For trolleys	Reference	Price
Cover	590 x 405 x 740	1/1 GN 6-8 tiers	221 235	£296
Cover	710 x 610 x 740	2/1 GN 6-8 tiers	221 236	£300
Cover	605 x 405 x 1325	1/1 GN 15 tiers	221 240	£310
Cover	725 x 610 x 1325	2/1 GN 15 tiers	221 241	£310
Cover	590 x 405 x 1620	1/1 GN 10-17-20 tiers	228 168	£230
Cover	710 x 610 x 1620	2/1 GN 10-17-20 tiers	228 169	£237



228 169

Disposable polyethylene covers for GN container trolleys

Disposable covers in polyethylene thickness 50 microns : delivered by box of 100 covers.

Description	For trolleys	Reference	Price.
100 polyethylene cover	GN 1/1	228 170	£304
100 polyethylene cover	GN 2/1	228 171	£431

TROLLEY FOR DISHWASHER BASKETS



Trolley with 8 tiers (for horizontal storage of dishwasher baskets).
Stainless steel construction. Square tubular leg 25 x 25 mm.
Continuous argon welded basket runners. 4 swivel wheels 125 mm,
2 brakes, with polyamide cover. Annular wheel guards.
Space between tiers : 189 mm.



Description	Overall dim. l x W x h (mm)	Reference	Price
Trolley with 8 tiers (for horizontal storage of dishwasher baskets)	630 x 630 x 1785	<u>804 193</u>	£657
Polyamide cover with zip for trolley 8 tiers	585 x 600 x 1620	221 231	£412



Speed Shelving



YOUR SHELVING LAYOUT SOFTWARE



**Easy
to use**

For optimum layout of your shelving. Speed Shelving enables you to draw up an estimate for your customer, transform it into an order and prepare the packaging.

EASY TO USE

Intuitive browsing. The parts are predefined, simple set-up for easily modified layouts. Possibility of printing out an estimate and drawing in Excel.

TRACEABILITY

The files are classed and accessible. The quotations can be easily changed, used to place the order and prepare the installation.

RELIABILITY

All the parameters of the room are taken into account: doors, necessary clearance, possible presence of evaporators, recess resulting from grooved plinths.

Available on www.tournus.com



Video !

20/09/04



The NF Food hygiene certification certifies the quality of the materials used for food contact and guarantees easy cleaning.



The NSF certification guarantees easy cleaning and safety to consumers.

SHELVING

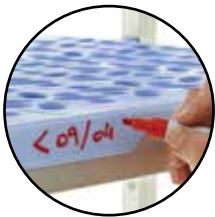

New shelf:
Innovative design
Overhanging shelves cover up the upper part of the aluminium bar, for an optimal fit.

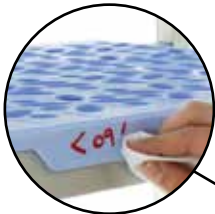

Tournus exclusive : there is a space at the edge of the shelves where white board erasable markers can be used to note the contents of the shelf, helps manage the stock of food.

Hygienic:
removable shelves, machine washable up to 90°C.

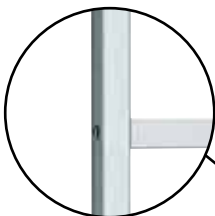

Sturdiness :
Uprights made of tubular anodised aluminium 32 x 30 mm.



Easy assembly:
by tapered self-locking insertion to strengthen the structure.



Load resistance :
150 kg evenly distributed per level.

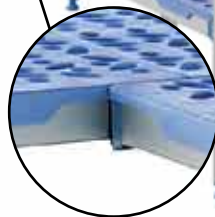
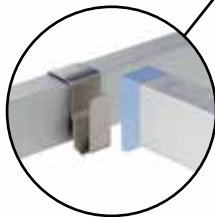

Stability :
Adjustable jacks without visible threading (hygienic).

Modular :
in line or corner type assembly.

Easy :
2 hooks per tier whatever the width 400, 500 or 560 mm.

Optimum accessibility :
the corner hook does away with the upright so as to store products in the corner.
Easy floor cleaning.



Shelving entirely recyclable



Speed Shelving

Shelving design software available on www.tournus.com/en/



Flash on our documentation !



**One person
alone
can assemble
5 metres
in 5 minutes
without tools**





RACKING WITH REMOVABLE SHELVES



Racking with removable shelves consist of shelves and uprights. Rapid assembly process, without tools, by simply snapping into place. Shaped assembly is possible by replacing an upright by corner hooks (2 corner hooks per tier). Load: up to 200 kg by level, 120 kg for the two higher lengths. NF Hygiene Certified. Operating temperature: -30°C à + 60°C. Shelving is washable in dishwasher (90°C) and fits over the top of the bar: nicer and more stable. It is also possible to write directly on the shelf with an erasable ink pen. Many accessories: Rear protection bar, separations, plates for fixing to the floor and walls.

TO PLACE AN ORDER: see pages 34 to 37 for the best prices of combinations for linear or angle assembly. **On request, each carton can be marked.** The combination price results from the addition of shelves, upright and angle hooks (if necessary).

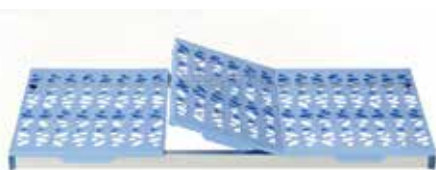

500 371

Removable polypropylene shelves

2 anodised aluminium bars and high density polypropylene shelves.



- Even more storage possibilities
- Solid shelves and shelves compatible with other models: possibility to mix shelves.

Lengths (mm)	Width 400 mm		Width 500 mm		Width 560 mm (GN)	
	Ref.	Price	Ref.	Price	Ref.	Price
608	<u>500 366</u>	£50	<u>500 386</u>	£59	<u>500 416</u>	£61
708	<u>500 367</u>	£53	<u>500 387</u>	£60	<u>500 417</u>	£65
808	<u>500 368</u>	£63	<u>500 388</u>	£64	<u>500 418</u>	£70
910	<u>500 369</u>	£72	<u>500 389</u>	£77	<u>500 419</u>	£80
1010	<u>500 370</u>	£77	<u>500 390</u>	£80	<u>500 420</u>	£84
1110	<u>500 371</u>	£81	<u>500 391</u>	£83	<u>500 421</u>	£88
1210	<u>500 372</u>	£84	<u>500 392</u>	£85	<u>500 422</u>	£93
1312	<u>500 373</u>	£93	<u>500 393</u>	£97	<u>500 423</u>	£105
1412	<u>500 374</u>	£97	<u>500 394</u>	£99	<u>500 424</u>	£110
1512	<u>500 375</u>	£100	<u>500 395</u>	£105	<u>500 425</u>	£114
1612	<u>500 376</u>	£107	<u>500 396</u>	£110	<u>500 426</u>	£120
1714	<u>500 377</u>	£116	<u>500 397</u>	£120	<u>500 427</u>	£129





500 124



Uprights

In aluminium with screwed fixing studs determining the number of tiers.



Height 1750 mm	Width 400 mm		Width 500 mm		Width 560 mm (GN)	
	Ref.	Price	Ref.	Price	Ref.	Price
3 tier	<u>500 103</u>	£119	<u>500 123</u>	£123	<u>500 153</u>	£128
4 tier	<u>500 104</u>	£121	<u>500 124</u>	£126	<u>500 154</u>	£129
5 tier	<u>500 105</u>	£128	<u>500 125</u>	£130	<u>500 155</u>	£133

Uprights on wheels

2 swivel wheels with ball bearings diameter 125 mm polyamid cover including 1 brake. Load maxi 100 kg/level.



Height 1750 mm	Width 400 mm		Width 500 mm		Width 560 mm (GN)	
	ref.	price	ref.	price	ref.	price
3 tier with wheels	-	-	<u>500 133</u>	£201	<u>500 163</u>	£207
4 tier with wheels	-	-	<u>500 134</u>	£206	<u>500 164</u>	£208
5 tier with wheels	-	-	<u>500 135</u>	£209	<u>500 165</u>	£213

Dunnage rack

2 low uprights + 1 polypropylene shelf.



500 847

Description	Overall dim. L x W x H (mm)	Reference	Price
Dunnage rack 1 tier	890 x 500 x 300	500 844	£346
Dunnage rack 1 tier	1192 x 500 x 300	500 847	£349
Dunnage rack 1 tier	1494 x 500 x 300	500 850	£377



SHELVING ASSEMBLIES (STRAIGHT RUN)

Height 1750 mm - Polypropylene shelves



To place an order:

Please indicate the depth code followed by the overall length required.

PLE 1594

Depth Length



For shelving on wheels: (500 and 560 mm deep only).

Add the suffix R at the end of the reference (e.g.: PLE 1594R).

Price of the whole combination on wheels: add £ 52 for every upright to the price of the whole combination per leg (above).

Overall length (mm)	Combinations	Depth 400 mm			Depth 500 mm			Depth 560 mm (GN)		
		3 tier PLA	4 tier PLB	5 tier PLC	3 tier PLD	4 tier PLE	5 tier PLF	3 tier PLG	4 tier PLH	5 tier PLI
690	608	£384	£436	£497	£419	£483	£549	£414	£472	£534
790	708	£395	£457	£522	£422	£489	£556	£433	£495	£565
890	808	£422	£492	£567	£436	£507	£580	£460	£532	£609
992	910	£452	£530	£615	£469	£549	£634	£488	£568	£656
1092	1010	£460	£542	£628	£480	£562	£649	£506	£594	£686
1192	1110	£474	£557	£652	£492	£580	£674	£521	£610	£708
1292	1210	£488	£578	£675	£501	£594	£687	£534	£629	£731
1394	1312	£517	£616	£722	£534	£635	£741	£566	£674	£787
1494	1412	£524	£626	£734	£543	£647	£756	£579	£689	£810
1594	1512	£540	£644	£757	£555	£666	£776	£594	£708	£832
1694	1612	£550	£664	£777	£570	£684	£801	£610	£732	£863
1728	808+808	£729	£864	£1,007	£753	£887	£1,031	£795	£934	£1,086
1796	1714	£579	£700	£827	£601	£728	£853	£638	£769	£908
1830	808+910	£756	£900	£1,054	£784	£932	£1,084	£819	£972	£1,131
1932	910+910	£784	£936	£1,098	£815	£975	£1,138	£846	£1,009	£1,178
2032	910+1010	£795	£948	£1,113	£826	£986	£1,153	£869	£1,032	£1,209
2132	1010+1010	£801	£960	£1,128	£835	£998	£1,169	£884	£1,057	£1,237
2232	910+1210	£819	£983	£1,157	£846	£1,018	£1,190	£893	£1,068	£1,256
2334	910+1312	£846	£1,021	£1,207	£880	£1,060	£1,244	£925	£1,112	£1,307
2432	1110+1210	£843	£1,017	£1,196	£872	£1,046	£1,228	£925	£1,112	£1,307
2532	1210+1210	£854	£1,033	£1,222	£880	£1,060	£1,244	£938	£1,130	£1,331
2634	1210+1312	£884	£1,070	£1,265	£912	£1,102	£1,300	£972	£1,173	£1,383
2736	1312+1312	£912	£1,108	£1,311	£945	£1,146	£1,350	£1,004	£1,217	£1,438
2834	1210+1512	£908	£1,101	£1,305	£934	£1,134	£1,336	£998	£1,211	£1,429
2936	1312+1512	£934	£1,138	£1,349	£967	£1,175	£1,387	£1,031	£1,253	£1,482
3036	1412+1512	£945	£1,150	£1,366	£977	£1,187	£1,405	£1,043	£1,270	£1,506
3136	1512+1512	£958	£1,169	£1,386	£989	£1,208	£1,428	£1,059	£1,289	£1,527
3172	1010+1010+1010	£1,144	£1,379	£1,629	£1,189	£1,437	£1,687	£1,262	£1,520	£1,792
3236	1512+1612	£972	£1,185	£1,413	£1,004	£1,225	£1,450	£1,078	£1,312	£1,560
3272	910+1110+1110	£1,163	£1,405	£1,659	£1,209	£1,459	£1,718	£1,272	£1,531	£1,805
3336	1612+1612	£983	£1,207	£1,435	£1,018	£1,241	£1,475	£1,094	£1,337	£1,589
3372	1010+1110+1110	£1,172	£1,418	£1,673	£1,219	£1,474	£1,731	£1,290	£1,557	£1,838
3438	1612+1714	£1,014	£1,240	£1,480	£1,047	£1,286	£1,526	£1,123	£1,374	£1,636
3472	1010+1110+1210	£1,184	£1,437	£1,697	£1,226	£1,483	£1,749	£1,305	£1,577	£1,860
3540	1714+1714	£1,040	£1,277	£1,525	£1,082	£1,329	£1,579	£1,150	£1,413	£1,683
3572	1110+1110+1210	£1,197	£1,452	£1,720	£1,238	£1,504	£1,771	£1,317	£1,595	£1,880
3674	1110+1110+1312	£1,226	£1,490	£1,767	£1,272	£1,548	£1,826	£1,349	£1,637	£1,937
3772	1210+1210+1210	£1,226	£1,490	£1,767	£1,259	£1,526	£1,802	£1,345	£1,631	£1,930
3812	910+910+910+910	£1,449	£1,754	£2,069	£1,510	£1,825	£2,144	£1,567	£1,888	£2,220
3876	1110+1312+1312	£1,268	£1,548	£1,837	£1,312	£1,600	£1,894	£1,396	£1,697	£2,012
3912	910+910+910+1010	£1,458	£1,763	£2,084	£1,518	£1,837	£2,160	£1,586	£1,911	£2,252
3976	1210+1312+1312	£1,282	£1,563	£1,859	£1,322	£1,613	£1,908	£1,409	£1,717	£2,035
4078	1312+1312+1312	£1,308	£1,600	£1,905	£1,355	£1,654	£1,962	£1,442	£1,759	£2,092
4178	1312+1312+1412	£1,317	£1,613	£1,917	£1,363	£1,666	£1,977	£1,453	£1,777	£2,111
4278	1312+1312+1512	£1,332	£1,631	£1,942	£1,377	£1,686	£1,999	£1,468	£1,797	£2,135
4378	1412+1412+1412	£1,336	£1,637	£1,949	£1,381	£1,693	£2,008	£1,482	£1,813	£2,158
4478	1312+1512+1512	£1,355	£1,661	£1,979	£1,401	£1,717	£2,039	£1,495	£1,831	£2,182
4578	1412+1512+1512	£1,363	£1,672	£1,995	£1,409	£1,728	£2,053	£1,511	£1,850	£2,203
4612	1110+1110+1110+1110	£1,538	£1,871	£2,220	£1,600	£1,944	£2,298	£1,696	£2,057	£2,436
4678	1312+1612+1612	£1,381	£1,697	£2,025	£1,428	£1,755	£2,084	£1,531	£1,878	£2,242
4712	1110+1110+1110+1210	£1,555	£1,893	£2,244	£1,610	£1,957	£2,314	£1,711	£2,075	£2,456
4778	1512+1512+1612	£1,390	£1,711	£2,041	£1,438	£1,766	£2,099	£1,542	£1,894	£2,256
4814	1110+1110+1110+1312	£1,580	£1,930	£2,290	£1,643	£1,999	£2,366	£1,742	£2,120	£2,511
4878	1512+1612+1612	£1,405	£1,728	£2,064	£1,450	£1,783	£2,122	£1,561	£1,916	£2,288
4914	1110+1110+1210+1312	£1,596	£1,946	£2,314	£1,650	£2,012	£2,380	£1,757	£2,137	£2,535
4978	1612+1612+1612	£1,419	£1,748	£2,086	£1,465	£1,802	£2,144	£1,578	£1,942	£2,318

SHELVING ASSEMBLIES (ANGLED RUN)

Height 1750 mm - Polypropylene shelves

Shipment within 5-7 days
5-7 DAYS

To place an order:

Please indicate depth code followed by the overall length required.

PCE 1553
Depth Length

The reference and the price include the angle hooks.



Overall length (mm)	Combinations	Depth 400 mm			Depth 500 mm			Depth 560 mm (GN)		
		3 tier PCA	4 tier PCB	5 tier PCC	3 tier PCD	4 tier PCE	5 tier PCF	3 tier PCG	4 tier PCH	5 tier PCI
649	608	£282	£342	£403	£315	£384	£452	£304	£369	£432
749	708	£298	£360	£424	£320	£388	£459	£326	£390	£461
849	808	£326	£395	£472	£334	£408	£482	£350	£428	£507
951	910	£350	£433	£519	£365	£451	£535	£379	£463	£551
1051	1010	£361	£446	£532	£375	£461	£549	£398	£489	£584
1151	1110	£375	£462	£554	£388	£481	£574	£412	£507	£606
1251	1210	£388	£482	£578	£398	£492	£590	£424	£525	£629
1353	1312	£415	£520	£623	£431	£535	£640	£458	£568	£683
1453	1412	£424	£531	£638	£437	£547	£657	£472	£589	£704
1553	1512	£437	£548	£663	£453	£566	£681	£484	£604	£729
1653	1612	£453	£567	£684	£466	£584	£702	£502	£629	£760
1687	808+808	£629	£767	£910	£647	£790	£932	£684	£832	£982
1755	1714	£481	£602	£730	£497	£626	£756	£531	£666	£803
1789	808+910	£657	£802	£957	£681	£832	£983	£712	£870	£1,028
1891	910+910	£684	£840	£1,003	£712	£875	£1,039	£738	£904	£1,077
1991	910+1010	£692	£849	£1,018	£723	£885	£1,055	£757	£930	£1,107
2091	1010+1010	£702	£866	£1,032	£730	£899	£1,068	£774	£953	£1,137
2191	910+1210	£723	£887	£1,064	£743	£917	£1,092	£787	£966	£1,152
2293	910+1312	£748	£925	£1,110	£774	£959	£1,146	£816	£1,009	£1,207
2391	1110+1210	£743	£920	£1,101	£767	£947	£1,130	£816	£1,009	£1,207
2491	1210+1210	£757	£937	£1,124	£774	£959	£1,146	£832	£1,026	£1,227
2593	1210+1312	£787	£975	£1,171	£810	£1,003	£1,197	£864	£1,068	£1,282
2695	1312+1312	£813	£1,011	£1,217	£840	£1,043	£1,253	£894	£1,112	£1,334
2793	1210+1512	£810	£1,006	£1,209	£832	£1,032	£1,236	£889	£1,107	£1,328
2895	1312+1512	£836	£1,041	£1,256	£864	£1,077	£1,290	£922	£1,149	£1,379
2995	1412+1512	£844	£1,055	£1,269	£873	£1,087	£1,306	£936	£1,168	£1,404
3095	1512+1512	£859	£1,071	£1,292	£885	£1,107	£1,329	£950	£1,184	£1,425
3131	1010+1010+1010	£1,043	£1,285	£1,531	£1,086	£1,334	£1,587	£1,154	£1,418	£1,689
3195	1512+1612	£873	£1,091	£1,313	£900	£1,124	£1,350	£968	£1,211	£1,457
3231	910+1110+1110	£1,064	£1,308	£1,563	£1,104	£1,360	£1,619	£1,164	£1,429	£1,704
3295	1612+1612	£885	£1,110	£1,337	£913	£1,143	£1,374	£986	£1,233	£1,487
3331	1010+1110+1110	£1,071	£1,321	£1,578	£1,113	£1,371	£1,634	£1,181	£1,452	£1,732
3397	1612+1714	£913	£1,146	£1,383	£946	£1,184	£1,428	£1,016	£1,270	£1,531
3431	1010+1110+1210	£1,086	£1,340	£1,601	£1,123	£1,383	£1,649	£1,195	£1,474	£1,758
3499	1714+1714	£942	£1,181	£1,429	£978	£1,227	£1,481	£1,041	£1,307	£1,578
3531	1110+1110+1210	£1,099	£1,359	£1,624	£1,137	£1,402	£1,671	£1,211	£1,490	£1,779
3633	1110+1110+1312	£1,127	£1,395	£1,670	£1,169	£1,445	£1,725	£1,240	£1,531	£1,832
3731	1210+1210+1210	£1,127	£1,395	£1,670	£1,154	£1,425	£1,702	£1,236	£1,526	£1,827
3771	910+910+910+910	£1,349	£1,654	£1,974	£1,405	£1,722	£2,047	£1,459	£1,783	£2,120
3835	1110+1312+1312	£1,169	£1,449	£1,740	£1,211	£1,502	£1,796	£1,288	£1,595	£1,910
3871	910+910+910+1010	£1,360	£1,666	£1,988	£1,416	£1,732	£2,061	£1,479	£1,806	£2,149
3935	1210+1312+1312	£1,181	£1,467	£1,761	£1,220	£1,512	£1,807	£1,302	£1,613	£1,935
4037	1312+1312+1312	£1,211	£1,505	£1,806	£1,252	£1,555	£1,863	£1,333	£1,654	£1,987
4137	1312+1312+1412	£1,220	£1,516	£1,825	£1,260	£1,565	£1,876	£1,347	£1,672	£2,010
4237	1312+1312+1512	£1,232	£1,534	£1,846	£1,273	£1,585	£1,902	£1,361	£1,693	£2,033
4337	1412+1412+1412	£1,236	£1,538	£1,855	£1,277	£1,592	£1,908	£1,374	£1,711	£2,054
4437	1312+1512+1512	£1,257	£1,564	£1,883	£1,296	£1,615	£1,939	£1,386	£1,728	£2,076
4537	1412+1512+1512	£1,263	£1,577	£1,901	£1,306	£1,628	£1,954	£1,402	£1,748	£2,100
4571	1110+1110+1110+1110	£1,442	£1,777	£2,124	£1,495	£1,845	£2,198	£1,587	£1,954	£2,332
4637	1312+1612+1612	£1,283	£1,601	£1,931	£1,324	£1,651	£1,985	£1,423	£1,777	£2,140
4671	1110+1110+1110+1210	£1,453	£1,797	£2,148	£1,506	£1,857	£2,213	£1,601	£1,974	£2,356
4737	1512+1512+1612	£1,292	£1,614	£1,944	£1,333	£1,664	£1,999	£1,435	£1,789	£2,154
4773	1110+1110+1110+1312	£1,482	£1,831	£2,193	£1,536	£1,901	£2,267	£1,634	£2,014	£2,408
4837	1512+1612+1612	£1,306	£1,632	£1,968	£1,347	£1,684	£2,023	£1,451	£1,813	£2,185



ACCESSORIES



123 014



800 711



500 817



500 813



118 728



120 797



Separation



Rear protection bar



230 653

Description	Reference	Price
Corner unit	<u>123 014</u>	£4.36
Supplementary studs (each)	800 711	£7
1/1 GN pan holder with tray runners (34 mm height gap between)	500 817	£266
Hook-on label - holder	500 813	£26
Floor fixing plate	118 728	£9
Wall fixing plate	120 797	£9
Separation width 400 mm (per pair)	500 814	£59
Separation width 500 mm (per pair)	500 815	£65
Separation width 560 mm (per pair)	500 816	£71
Rear protection bar, 808 mm long	500 783	£60
Rear protection bar, 910 mm long	500 784	£63
Rear protection bar, 1010 mm long	500 785	£65
Rear protection bar, 1110 mm long	500 786	£66
Rear protection bar, 1210 mm long	500 787	£70
Rear protection bar, 1312 mm long	500 788	£71
Rear protection bar, 1412 mm long	500 789	£72
Rear protection bar, 1512 mm long	500 790	£72
Rear protection bar, 1612 mm long	500 791	£77
Rear protection bar, 1714 mm long	500 792	£77
Polypropylene grids W 380 x L 300 mm	<u>230 643</u>	£17
Polypropylene grids W 380 x L 400 mm	<u>230 644</u>	£22
Polypropylene grids W 480 x L 300 mm	<u>230 653</u>	£22
Polypropylene grids W 480 x L 400 mm	<u>230 654</u>	£22
Polypropylene grids W 550 x L 300 mm	<u>230 663</u>	£22
Polypropylene grids W 550 x L 400 mm	<u>230 664</u>	£29

PALLETS

Stackable polyethylene pallets, food quality. Maximum load (static): 4 tons (reference 806 105), 500 kg (reference 806 106).

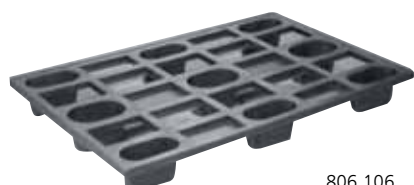

806 106

Description	Overall dimensions W x l (mm)	Reference	Price
Polyethylene pallet, grey flat base	1200 x 800	806 105	£334
Polyethylene pallet, black slatted base	1200 x 800	806 106	£85



SHELVING - POLYPROPYLENE SHELVES



Angled run



Straight run

Wide choice :
manual, electronic
soap dispenser, soap
pump.



Ergonomics and sustainable development :
tap with infra red detection cell made in France.
Reduced water consumption thanks to immediate
stop of flow on removal of hands.



Also available with
knee-operated tap



Easier installation :
thanks to the fixing strip
at the rear of the splash-back



Hygienic :
oversized basin (350 x 275 mm,
depth 80 mm).



Eye-catching :
one-piece. The basin, lip and
backplash assembly is made in
one piece. Streamlined design.



Insert bin :
This recess allows straightforward installation of the
wash basin, regardless of the room taken up by the
water inlet and evacuation pipe.



Complete kit :
comes as standard with nail brush,
bin, electronic tap, connection
hoses, sink pipe trap and wall
bracket.



Scan here for
documentation

Hand wash basins - Sterilizing cabinets - Insect killers - Dustbins...





TS 2000N HAND WASH BASINS (W.R.A.S. APPROVED)



806 301

Food quality stainless steel construction monobloc. Hand wash basins supplied with nailbrush and bin under the basin for the disposal of used hand towels. Well 350 x 275 mm, depth 80 mm. Mixer tap with non-return valves and temperature setting. Supplied with 2 flexible hoses, trap and wall fixing support. The bin includes a recess at the back for easy installation. NF-Hygiene Certified.

TS 2000N WITH ELECTRONIC CONTROL

Electronically controlled mixer tap, made in France, triggered by infra red detection cell. Automatic opening and closing of tap immediately after hands are placed in front of or removed from the cell, without timer for water saving. The tap also has an aerator giving a softer stream of water which also reduces water consumption.

Battery-operated TS 2000N

Wash basin supplied with CR-P2, 6 volt batteries, service life: 350,000 presses, 3 years



Reduced water consumption,
only 3 litres per minute

Description	Overall dim. l x W x h(mm)	Reference	Price
TS 2000N with electronic control	400 x 400 x 755	806 301	£1,167
TS 2000N with electronic control + manual soap dispenser (500 ml)	400 x 400 x 755	<u>806 302</u>	£1,233
TS 2000N with electronic control + integrated soap dispenser (500 ml)	400 x 400 x 755	<u>806 304</u>	£1,304

6 volt battery - Ref: 262 620 - Price.: £64

Mains supply TS 2000N

Wash basin with transformer for mains connection (230 V single phase).

Description	Overall dim. l x W x h(mm)	Reference	Price
TS 2000N with electronic control + transformer	400 x 400 x 755	806291UK	£1,460
TS 2000N with electronic control with manual soap dispenser (500 ml) + transformer	400 x 400 x 755	806292UK	£1,525
TS 2000N with electronic control with integrated soap dispenser (500 ml) + transformer	400 x 400 x 755	806294UK	£1,595



806 302



806 304



TS 2000N KNEE-OPERATED



Push button with oversized control paddle, positioned on front panel.



806 321



Description	Overall Dim. l x W x h(mm)	Reference	Price
TS 2000N knee-operated	400 x 440 x 755	806 321	£730
TS 2000N knee-operated + manual soap dispenser (500 ml)	400 x 440 x 755	806 322	£800
TS 2000N knee-operated + integrated soap dispenser (500 ml)	400 x 440 x 755	806 324	£814



806 322



806 324

TS 2000N : EASIER INSTALLATION



Easy fitting :

Thanks to the screw fixed wall mounting bracket which locates the bowl. Taps can be assembled before the bowl is installed.

This recess allows straightforward installation of the wash basin, regardless of the room taken up by the water inlet and evacuation pipes at the rear.





G.A. WASH HAND BOWLS (KNEE OPERATED)

W.R.A.S. approved, stainless steel construction. Well Ø 275 mm, depth 115 mm. Knee-operated control. Mixer tap with non-return valve and temperature setting. Supplied with siphon and flexible connecting hose for connection of mitigated water to swan neck. Soap dispenser 500 ml.



"GA" hand wash bowl	Overall dim. l x W x h (mm)	Reference	Price
Without upstand	330 x 330 x 170	<u>806 331</u>	£295
With upstand	350 x 330 x 500	<u>806 332</u>	£317
With upstand and soap dispenser	350 x 330 x 500	<u>806 333</u>	£385

G.C. WASH HAND BASINS (KNEE OPERATED)

W.R.A.S. approved, stainless steel construction. Well 345 x 245 mm, depth 120 mm. Mixer tap with non-return valves and temperature setting. Supplied with siphon and flexible connecting hose for connection of mitigated water to swan neck. Soap dispenser 500 ml.



G.C. wash hand basin (knee operated)

Operated by push button behind control paddle on front.



"GC" hand wash-basin	Overall dim. l x W x h (mm)	Reference	Price
Without upstand	415 x 310 x 185	<u>806 381</u>	£325
With upstand height 540 mm	440 x 335 x 540	<u>806 382</u>	£379
With upstand height 540 mm and soap dispenser	440 x 335 x 540	<u>806 383</u>	£451
With upstand height 540 mm + soap dispenser and stainless steel bin	440 x 335 x 985	<u>806 397</u>	£657
With upstand height 790 mm	440 x 335 x 790	806 384	£400
With upstand height 790 mm, soap dispenser and paper towel dispenser	440 x 335 x 790	<u>806 385</u>	£527

G.C. wash hand basin (electronic control)

Mixer tap, made in France, tripped by infrared detection cell.



"GC" hand wash-basin	Overall Dim. l x W x h (mm)	Reference	Price
Without upstand	415 x 310 x 185	<u>806 351</u>	£866
With upstand height 540 mm	440 x 335 x 540	<u>806 352</u>	£882
With upstand height 540 mm and soap dispenser	440 x 335 x 540	<u>806 353</u>	£986





MOBILE WASH HAND BASINS (FOOT OPERATED)

Stainless steel construction. 2 fixed wheels and handle for easy moving.

Basin 345 x 245 mm, depth 115 mm. Foot control. 2 cans of 13 litres (one for clear water, one for waste water). Supplied with manual soap dispenser 500 ml, paper towel dispenser (one towel roll Ø 120 mm, length 208 mm, supplied), hook-on dustbin.

Mobile foot operated wash hand basin, ref. 806 517: electric foot pump powered by 2 batteries 6 V supplied.

Mobile foot operated wash hand basin with built-in-water heater, ref. 806 519: integrated electric water heater for instant hot water production. Selection button for continuous adjustment of cold water to hot water and vice versa (up to 45°C). Supplied with 230 V 16 amp connection. Power rating 3.7 kW. Operational stop facility to protect the water heater when there is no water in the jerrycan.



806 517



806 519



Description	Overall Dim. l x W x h (mm)	Reference	Price
Mobile foot operated wash hand basin	415 x 345 x 1200	806 517	£1,185
Mobile foot operated wash hand basin with built-in water heater	415 x 345 x 1200	806 519	£3,296

JANITOR SINK STATIONS

The Tournus s/steel mop and bucket station is available either 600 or 700 mm deep, to suit differing mop bucket sizes.

The top tier features a formed steel basin and plug for mop rinsing, with a lower sink area for locating the bucket, whilst filling or emptying.

The lower sink area has a removable perforated steel trivet stand to locate the bucket on. Both zones can be filled from the swivel neck mono-bloc mixer tap. They are supplied with PVC basin trap and strainer waste overflow tube.



806 536

Description	Overall Dim. l x W x h (mm)	Reference	Price
Janitor sink (600mm wide)	500 x 600 x 890	<u>806 536</u>	£1,113
Janitor sink (700mm wide)	500 x 700 x 890	806 537	£1,658



ACCESSORIES FOR TS 2000N / G.A. AND G.C. WASH HAND BASINS & BOWLS



806 314



806 350

Description	Overall dim. l x W x h (mm)	Reference	Price
Stainless steel wall dustbin	290 x 200 x 300	806 395	£114
Plastic wall dustbin	250 x 200 x 400	806 396	£54
Paper towel dispenser, capacity 250 towels (1)	280 x 130 x 370	230 552	£78
Box of 3000 towels, 30 packets of 100	300 x 290 x 145	230 398	£197
Paper towel dispenser for rolls Ø 120 mm	140 x 155 x 290	230 553	£78
Box of 12 paper towel rolls Ø 120 mm	h = 210	806 362	£193
Paper towel dispenser for rolls Ø 170 mm	210 x 220 x 320	230 554	£116
Box of 6 paper towel rolls Ø 170 mm	h = 195	806 364	£149
Nails brush on support		806 314	£15
Soap dispenser 500 ml	95 x 95 x 165	<u>230 469</u>	£70
Extra-cost for plug and brass tap + brass siphon		230 234	£71
Mixer tap with electronic control, flow rate 3l/mn		<u>230 507</u>	£635
Knee-control kit: control by rod + swan neck, flexible tube. Enables conversion an existing basin.		806 350	£736

(1) Attached to the upstand height 790 mm or the wall



STERILIZING CABINETS

Stainless steel construction, rounded edges, transparent Plexiglass doors, stainless steel hinge, magnetic lock. Sloping top and bottom, interior support bar. Control button to outside of cabinet. Timer adjustable from 0 to 2 h. U.V. tube with automatic U.V. radiation cut-off system when door is opened. Index of protection IP 24. Voltage 230 V.



806 421



806 422



806 423



Looking door shown



806 424



Description	Overall dim. l x w x h (mm)	Without key		With key	
		Ref.	Price	Ref.	Price
Lockable 1 door, 20 knife sterilizing cabinet (storage in folded slotted steel grid)	575 x 170 x 600	806421UK	£704	816421AS	£774
Lockable 1 door, 10 knife sterilizing cabinet (storage on magnetized bar)	575 x 170 x 600	806422UK	£727	816422AS	£800
Lockable 1 door, 20 knife sterilizing cabinet (storage in s/steel wire bar frame)	575 x 170 x 600	806423UK	£762	816423AS	£826
Lockable 2 door, 40 knife sterilizing cabinet (storage in s/steel wire bar frame)	1030 x 170 x 600	806424UK	£1,233	816424AS	£1,337

UV tubes

Description	Reference	Price
Tube 15 W, length 440 mm for 575 mm (L) sterilizing cabinet	262 170	£35
Tube 30 W, length 900 mm for 1030 mm (L) sterilizing cabinet	262 172	£53





WASTE BAG HOLDERS & BINS

Mobile bag holder features

Made of stainless steel 20 mm diameter tubing.. Very rigid bag support consisting of a 4 mm stainless steel flat bar and an elastic strap bag fixing system. Strong and reliable lid opening system consisting of a stainless steel pedal connected to a double stainless steel rod. Injection moulded polypropylene lid, rigid and silent in operation. 2 smooth wheels Ø 150 mm. Generously-sized manoeuvring handle. Rigid stainless steel surround with hinged door and latch.



804 465

804 460



804 468



804 452



804 476

Description	For bags (litres)	Height (mm)	Overall dim. l x W (mm)	Reference	Price
130L open frame bag holder (pedal lid)	100 - 130	900	450 x 535	804 465	£320
100L open frame bag holder (pedal lid)	50 - 100	700	450 x 535	804 464	£320
100L bag holder (pedal lid + steel surround)	100	900	450 x 535	804 468	£578
70L bag holder (pedal lid + steel surround)	70	700	450 x 535	804 467	£545
100L open frame bag holder (open neck)	50 - 100	800	450 x 505	804 460	£243

Waste bag holders (pedal clip)

Stainless steel construction. 2 swivel wheels Ø 80 mm. 2 feet made of stainless steel tube with non-slip rubber pads to the front. Stainless steel base to support the bag. Clip consisting of 2 stainless steel plates covered in rubber. Pedal operated opening.

Description	For bags (litres)	Height (mm)	Overall dim. l x W (mm)	Reference	Price
100L waste bag holders (pedal clip)	100	810	450 x 535	804 452	£379
110L waste bag holders (pedal clip)	110	970	450 x 535	804 453	£389

Description	Reference	Price
FOR MOBILE BAG HOLDERS		
Open frame bag holder, bag support tray	118 845	£70
For sorting waste: 5 colours segregated waste labels	296 298	£31
FOR MOBILE BAG HOLDERS WITHOUT SURROUND AND BAG HOLDERS WITH CLIP		
Roll holder Ø 100 mm, height 250 mm (2)	804 476	£206

- (1) : Don't fit for bag holders with surround.
 (2) : Supplied with elastic strap bag fixing system



118 845



296 298



804 395

Snack bar bin (hinged waste flap)

Waste bin for snack and fast food. Stainless steel construction. Top of unit fitted to take trays. Waste flap. Mobile stainless steel front with base at rear and very rigid flat surface 4 mm thick to hold bag. This device is designed for easy fitting and removal of the bag, held by an elastic strap.

Description	Capacity (litres)	Height (mm)	Overall dim l x W (mm)	Reference	Price
Snack bar bin (hinged waste flap)	110	1236	444 x 480	804 395	£2,225



804 405

Cylindrical bin (pedal lid)

Stainless steel construction. Lid with pedal. 2 swivel wheels.

Description	Capacity (litres)	Height (mm)	Ø (mm)	Reference	Price
Cylindrical bin (pedal lid)	50	610	370	804 405	£474
Cylindrical bin (pedal lid)	100	720	450	804 407	£545



906 505

Waste bin for fat and bones

Stainless steel construction. Open-ended cylinder, and an independant wheeled base. Lid with hook. 4 swivel wheels.

Description	Ø x H (mm)	Reference	Price
Waste bin for fat and bones, capacity 100 litres	470 x 755	906 505	£574

Sanitary containers

Polyethylene body and lid + padlock. Capacity 60 litres.



804 425

Description	Ø x H (mm)	Reference	Price
"Seizure" sanitary container	400 x 650	804 426	£225
Sanitary container for SRM (specified risk materials)	400 x 650	804 425	£221
Mobile circular, wheel-base for sanitary container	425 x 125	906 519	£221



804 426



906 519

BREAD MAKING UNITS



Hygienic:

Beech top to store pieces of dough or for natural proving in bread making.

Ergonomical:

Front door can be raised and stored under the work surface.

6 slide bar levels

CATERING HIGH CUPBOARD

Strength:

Reinforced sliding doors, suspended from a rail fixed on the upper part, with stop-blocks.

Modular:

adjustable shelf

Aesthetics :

Flattened folds used throughout, on the front edge and shelves.







BREAD MAKING UNITS

Stainless steel units, height 900 mm. Glued beech plywood top, 26 mm thick. Front door can be raised and stored under the work surface. 6 slide bar levels. 4 wheels Ø 125 mm with 2 brakes.



504 701

Description	Overall dim. L x P x H (mm)	Reference	Price
Bread making unit 800 x 600 mm	1025 x 800 x 900	504 700	£4,208
Bread making unit 900 x 700 mm	1025 x 800 x 900	504 701	£4,219
Stainless steel grids	800 x 600	805 087	£78
Stainless steel grids with reinforcements and stops	900 x 700	805 088	£119
Marine plywood	900 x 700 x 15	221 092	£304

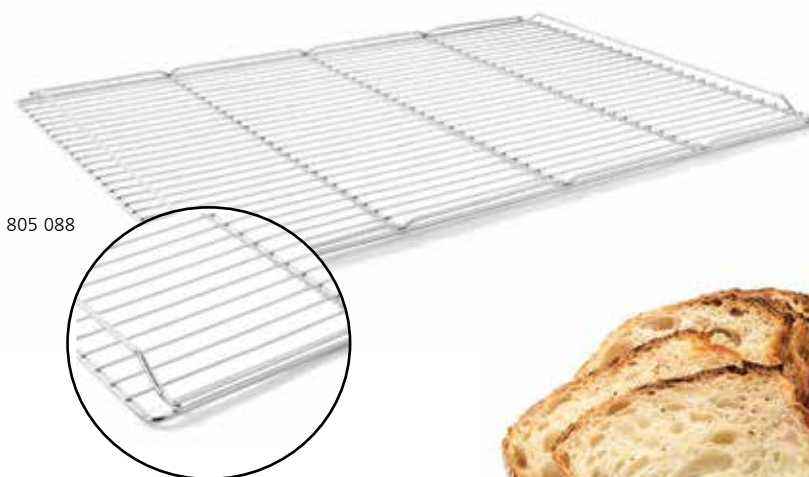

805 088





Wall shelves with racks

Stainless steel construction. Rack height: 1 tier 315 mm, 2 tier 700 mm, pitch 55 mm, fixed by screw. Adjustable trays, thickness 1.2 mm, rear upstand 50 mm high.

WIDTH 290 MM



509 974

Overall dim. W x l (mm)	Shelf 1 tier		Shelf 2 tier	
	Reference	Price	Reference	Price
290 x 800	509 971	£207	509 986	£387
290 x 1000	509 972	£210	509 987	£400
290 x 1200	509 973	£251	509 988	£474
290 x 1400	509 974	£251	509 989	£475
290 x 1500	509 975	£275	509 990	£546
290 x 1600	509 976	£288	509 991	£562
290 x 1800	509 977	£294	509 992	£548
290 x 2000	509 978	£284	509 993	£575
290 x 2200	509 979	£326	509 994	£634

WIDTH 390 MM



509 928

Overall dim. W x l (mm)	Shelf 1 tier		Shelf 2 tier	
	Reference	Price	Reference	Price
390 x 800	509 910	£223	509 925	£400
390 x 1000	509 911	£227	509 926	£444
390 x 1200	509 912	£252	509 927	£460
390 x 1400	509 913	£252	509 928	£484
390 x 1500	509 914	£282	509 929	£537
390 x 1600	509 915	£282	509 930	£537
390 x 1800	509 916	£301	509 931	£579
390 x 2000	509 917	£302	509 932	£591
390 x 2200	509 918	£369	509 933	£698

For other lengths: see price of the upper length.





CATERING HIGH CUPBOARD

Stainless steel construction, height 1800 mm. Reinforced sliding doors, suspended from a rail fixed on the upper part, with stop-blocks. Horizontal top. 3 adjustable shelves. Polyamide leg with jacks (no exposed thread). Flattened folds used throughout on the front edge, shelves, handles and floor.



503 493

Description	Dimensions W x l (mm)	Reference	Price
High cupboard with sliding doors	600 x 1000	503 492	£2,768
High cupboard with sliding doors	600 x 1200	503 493	£3,066

Option: Lock for catering wall cabinets and catering units and catering high cupboard
Ref.: 118 882 - Price **£56**

CATERING CUPBOARD FOR CLEANING PRODUCTS

Stainless steel construction, height 1800 mm. Reinforced 1 or 2 hinged doors with key. Horizontal top. Vertical separation. 3 adjustable half shelves + 1 lower fixed shelf. Polyamide leg.



Description	Dimensions W x l (mm)	Reference	Price
Cupboard 1 door with vertical separation	500 x 600	503 481	£1,862
Cupboard 2 doors with vertical separation	500 x 1000	503 482	£2,422
Additional shelf 1 door		121 989	£64
Additional shelf 2 doors		121 990	£76





BE AT THE BEST LEVEL WITH ERGONOMIX

Ergonomix is an adjustable worktop. It allows everyone to work at a height that suits them, depending on their size or the task. Ergonomix helps reduce the risk of musculoskeletal injury, a leading cause of work absence.

Easy to use

Manual operation of the crank makes it possible to raise or lower the platform according to the user's needs. There is no electrical connection required.

Ergonomic

After adjusting the height, the crank can be folded under the worktop, avoiding the risk of snagging or shocks.

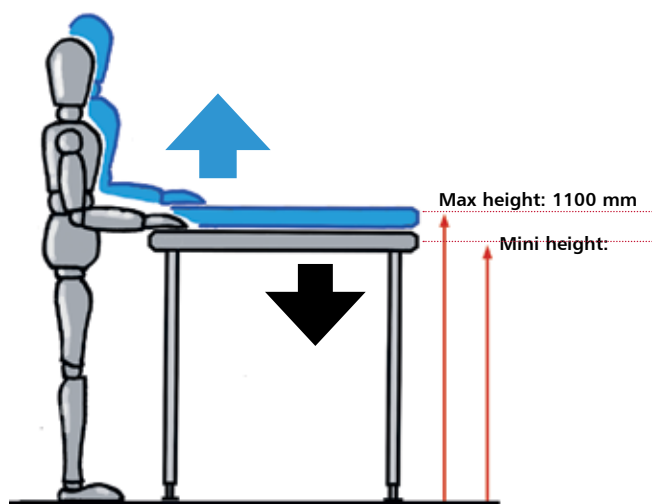

READY TO USE

The worktop is delivered ready to use. The product is already pre-assembled and checked in our factory. Just remove the packaging, clean the surface of the worktop and it's ready to use immediately by staff.





404 702

ERGONOMIX WORKTOPS

Stainless steel adaptable worktops. 1,5 mm top lined by laminated panel with aluminium under side tables. Free-standing **worktop with rounded front and rear edges**. Worktop with upstand: rear upstand, height 100 mm and rounded front edge, sliding pads attached to the back of the upstand for protection of the wall during ascent and descent. Feet: square stainless steel legs 40 × 40 mm. Hydraulic system (stroke 0 - 300 mm) controlled by a retractable crank. Removable stainless steel shelf 1.2 mm thickness, hookable on the spacers. 4 adjustable jacks for balancing. Worktops delivered ready to use.

Worktops on feet



424 712

Overall dim W × l (mm)	Free standing worktop		Free standing worktop + undershelf		With upstand		With upstand + undershelf	
	Ref.	Price	Ref.	Price	Ref.	Price	Ref.	Price
700 × 1000	404 701	£4,181	424 701	£4,391	404 711	£4,294	424 711	£4,505
700 × 1200	404 702	£4,251	424 702	£4,484	404 712	£4,368	424 712	£4,599
700 × 1400	404 703	£4,325	424 703	£4,577	404 713	£4,440	424 713	£4,693
700 × 1600	404 705	£4,440	424 705	£4,715	404 715	£4,556	424 715	£4,831
700 × 1800	404 706	£4,570	424 706	£4,866	404 716	£4,685	424 716	£4,982



464 712

Worktops on wheels

Overall dim W × l (mm)	Free standing worktop		Free standing worktop + undershelf		With upstand		With upstand + undershelf	
	Ref.	Price	Ref.	Price	Ref.	Price	Ref.	Price
700 × 1000	414 701	£4,302	464 701	£4,513	414 711	£4,418	464 711	£4,628
700 × 1200	414 702	£4,374	464 702	£4,606	414 712	£4,490	464 712	£4,722
700 × 1400	414 703	£4,447	464 703	£4,700	414 713	£4,592	464 713	£4,815
700 × 1600	414 705	£4,564	464 705	£4,838	414 715	£4,677	464 715	£4,952
700 × 1800	414 706	£4,693	464 706	£4,990	414 716	£4,808	464 716	£5,105



404 702
+ optional drawer

Accessory

Stainless steel drawer with facade with polypropylene GN 1/1 pan
Ref. [809 504](#), price: **£368**



Head Office
Lancashire



CED Fabrications Ltd
Units A1-A4, Falcon Court
Clayton Business Park
Clayton-le-Moors,
Hyndburn, Lancashire
BB5 5JD

T: 01254 238 282
F: 01254 238 228

T: 0151 545 2840

CED Fabrications Ltd,
Units 4 & 5,
Nexus Industrial Estate,
Randles Road, Knowsley
Prescot, Merseyside
L34 9HX



Manufacturing Plant
Merseyside



CED Fabrications Ltd
Building 3
Sandwich Industrial Estate
Sandwich, Kent
CT13 9LY

T: 01304 617 377



Manufacturing Plant
Kent



Certificate Number 7895
ISO 9001, ISO 14001

SALES LINE
01254 238 282

All prices exclude VAT - Free delivery applies to all orders over £350. All orders under £350 incur a £40 charge. Deliveries to UK mainland ONLY.

w: www.cedfabsltd.co.uk
e: sales@cedlimited.com



DOWNLOAD ALL
TECHNICAL DRAWINGS
from www.cedfabsltd.co.uk

Distributor stamp